

### General description

OC310x is an electric operated striker lock. Operation is based on electromagnet to control the striker lock. Design is continuously improved, refined and tested until failure to yield product with outstanding performance. Stringent quality control following ISO 9001 guarantees consistent reliability of this product. Optimized manufacturing flow allow OC310x to be a very cost competitive solution in the market.

### Application

Suitable for stainless steel door, wooden door, fireproof door in office building as well as residential premises. To be used together with anode mechanical and globular-shape lock.

### Feature

Side extension on front plate to cover up mounting hole on door frame for better cosmetic appearance after installation.

Top quality raw material processed using special unique techniques to ensure reliable performance over period of time using the product. This drastically reduce failure rate and any maintenance required.

Support an external diode (1N4007) to prevent recoil current to come out and damage the access control system.

### Technical specification

Parameter	Description
Power	DC 12V
Operating current	240 mA
Starting current	650 mA
Temperature	15° Celcius
Holding force	250 kg
Weight	0.35 kg
Max door opening	90°

### Dimension specification

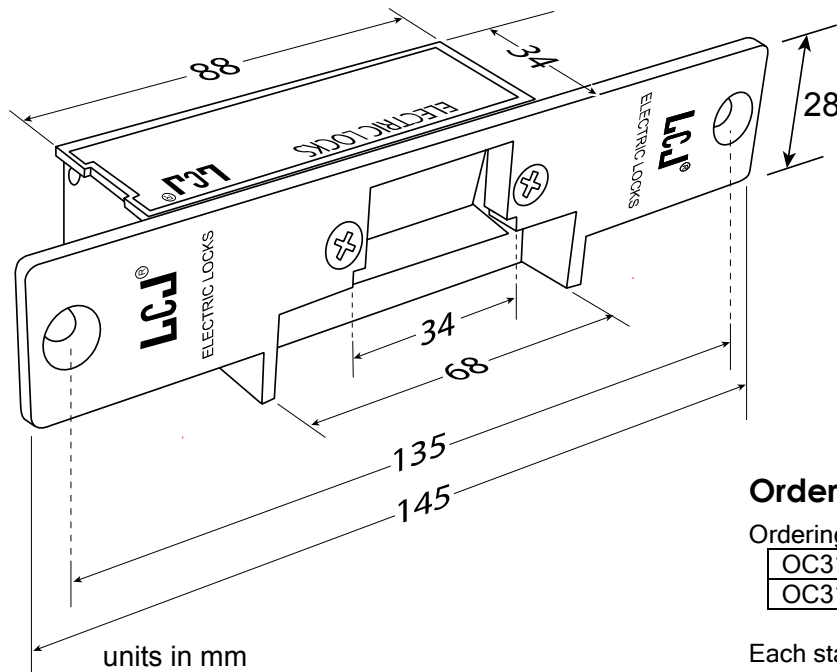

### Ordering information

Ordering code:

OC3101	Power to open, fail secure
OC3103	Power to lock, fail safe

Each standard package includes the following:

Qty	Parts
1 pcs	Electric striker
1 pcs	1N4007 diode
2 pcs	Self tapping screw
2 pcs	Long screw

## Installation diagram

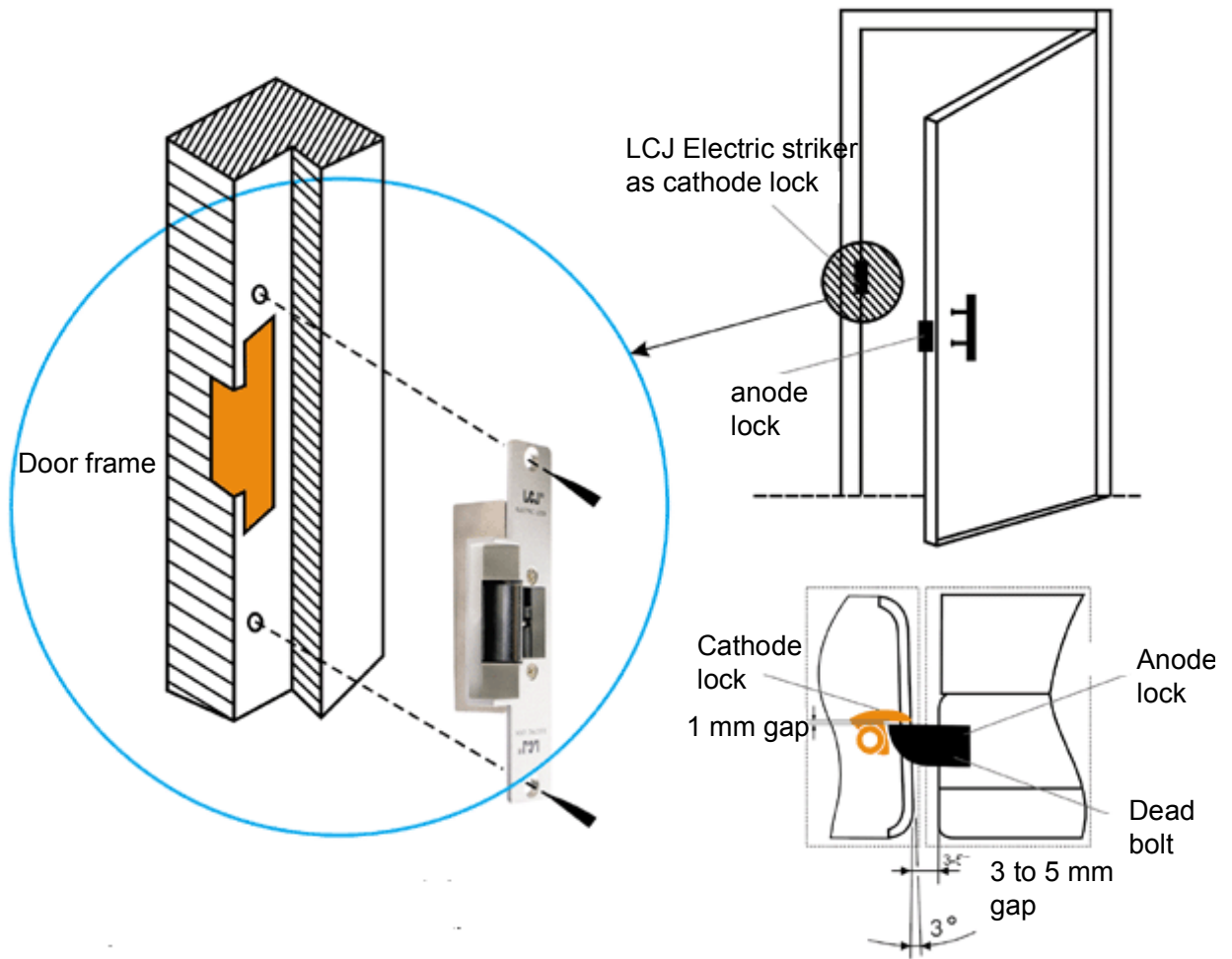

Installation precaution - in order to ensure proper opening of the door, please notice the following:

- Maintain 1-2 mm gap space between dead bolt of cathode lock and anode lock.
- Maintain 3-5 mm gap space between face plate of cathode lock and anode lock.

Refer to the above diagram for illustration.

## Packaging information

Standard package comes in a box that contains the lock and necessary screws. Each standard unit is approximately 0.35 kg. Box dimension is 45 mm x 155mm x 40 mm.

Distributor/installer: