

1200-LED

Electromagnet LOCK - 1200 lbs holding force with LED indicator

Revision: V1
Date: 20 Oct 2009



Description

The 1200 series electromagnetic locks are renowned with its excellent holding force and the remarkable features. The series compliance to UL, CE and PSB Test are manufactured under the highest quality control to achieve the commitment to customer who always satisfied with maximum quality and reliability.



Specification

- ▶ **Voltage Input:** 12 VDC / 24 VDC
- ▶ **Current Draw:** 12V / 500mA; 24V / 250mA (±5%)
- ▶ **Holding Force:** Up to 1200 lbs (545 kg)
- ▶ **Hall Effect Contact:** SPDT rated 2A at 24 VDC
- ▶ **Anti-Rust Surface Treatment:** Blue Zinc Plating
- ▶ **Operating Temperature:** 0~55° C (32~131° F)
- ▶ **Operating Humidity:** 0~95% (non condensing)
- ▶ **Weight (Magnet):** 2.5 kg (±1%)
- ▶ **Dimensions:** Magnet - (L) 266x (W) 67x (T) 39 mm
Armature - (L) 185x (W) 61x (T) 16.5



Features

- ▶ **Dual Voltage Selectable (12 VDC or 24 VDC)**
- ▶ **Low Current Consumption**
- ▶ **Reliable Holding Force**
- ▶ **Hall Effect Sensor Monitoring Output**
- ▶ **Green/Red LED Indication for EM Lock Status**
- ▶ **Durable and Silence Operation**
- ▶ **Cosmeticize Anodized Aluminum Casing**
- ▶ **Surge & Spike Protection PCB**
- ▶ **Anti-Tamper Jam Nuts**
- ▶ **Full Range of Optional Brackets**
- ▶ **Anti Residual Magnetism Kick Off Button**

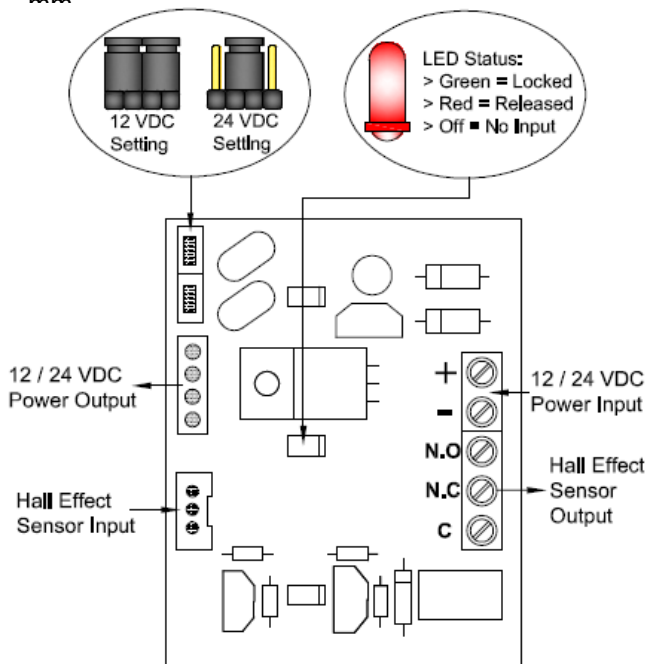

IMPORTANT!

Set the jumper position according to the power input correctly before switch ON the power.

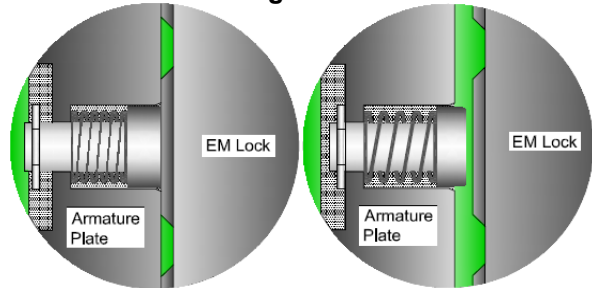

EM Lock Energized

EM Lock De-energized

Security.

Quality.

Reliability.