

# TTS310 Tripod Turnstile

## Stainless Steel Tripod Turnstile



Date: 20 Oct 2011, Revision: V1

### General Description

MAG TTS310 is an electro mechanical turnstile. Its unique mechanical drive design allows the arm to be pushed effortlessly and auto-rotate back without any expensive electric motor.

MAG TTS310 can effectively control high volume human traffic (up to 25 people per minute) while still maintaining a welcoming atmosphere. They can easily be integrated with any electronic system for ticketing, ESD, RFID access control or time attendance.

### Application

MAG TTS310 is suitable for indoor application only. It is **NOT** suitable to be installed outdoor or near sea side. They are optimized economical solution for railway, bus station, factory, colleges, commercial building, stadium, game park, banks and etc.

### Features

Mechanical drive unit eliminate the use of expensive electric motor and reduce maintenance cost. Lock mechanism is based on heavy duty solenoid to ensure longer life time and lesser maintenance.

Turnstile can be configured to be bi-directional or uni-directional. Built in acrylic plate for easy integration with other devices.

If arm rotate more than half, It will auto-rotate to the next idle position. If arm rotated less than half, it will auto-rotate back to the current idle position. Built in adjustable tension spring to control auto-rotate force of arm and minimize auto-rotation.

DC operation, built in circuit breaker to protect against mild electric surge.

### Maintenance

Recommended usage capacity is 7,000 rotations per day. Continuously exceeding this limitation may cause a few movable components to experience faster wear and tear than normal rate. Serviceable internal parts are as follows:

- a) Solenoid lock
- b) Roller bearing and spring
- c) Shock absorber
- d) Limit switch

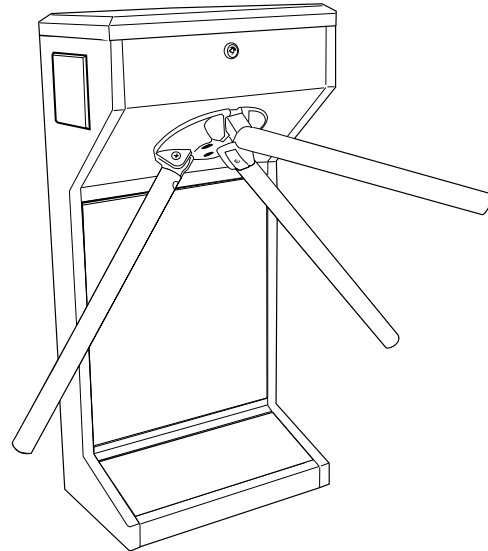

Anti-tailgating. Smart lock mechanism uses limit switch to detect rotation and effectively re-lock back after 1 person pass through. Also support time delay 5 sec, 10 sec, 15 sec and 60 sec.

During power failure, arm will drop automatically allowing free pass through. Internal parts inside the housing are locked via a key to avoid tampering.

Built in LED to indicate direction. Once unlock, arm just need to be pushed lightly to rotate therefore even elderly or children are able to use the turnstile.

## Technical specification

Description	Parameter
Power Supply Input	AC240 ± 10V
Power Voltage	24 V DC
Power Consumption During Idle	AC : 0.07 Amp DC : 0.16 Amp
Power Consumption During Operation	AC : 0.02 Amp DC : 0.72 Amp
Passage width	60 cm
Response Time	0.3 second
Pass Speed	25 person per minute
Housing / Arm	Stainless Steel
Internal Mechanism	Mild Steel
Arm Disc	Alloy chromed

## Dimension Specification

Top View

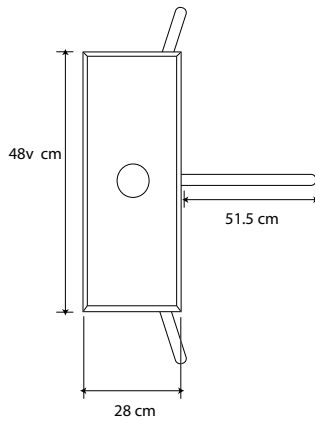

Front View

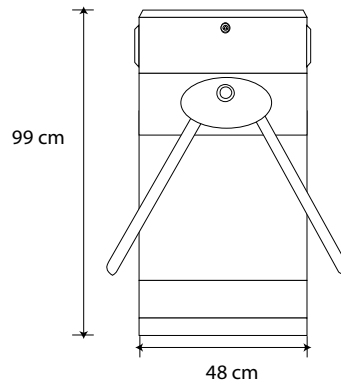

Side View

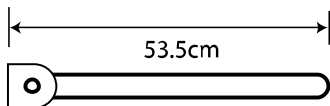
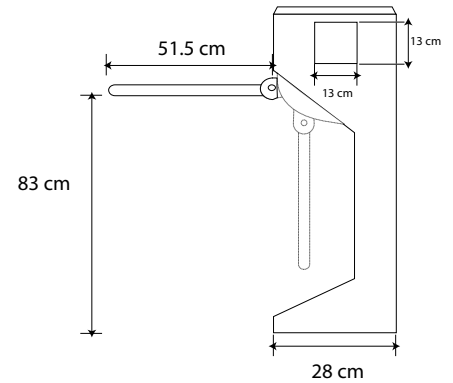

All tripod length are 53.5cm

## LED Display Pattern



Direction from  
Left

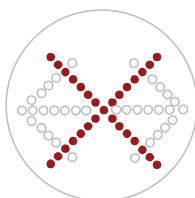

Default



Direction from  
Right

# Installation Diagram

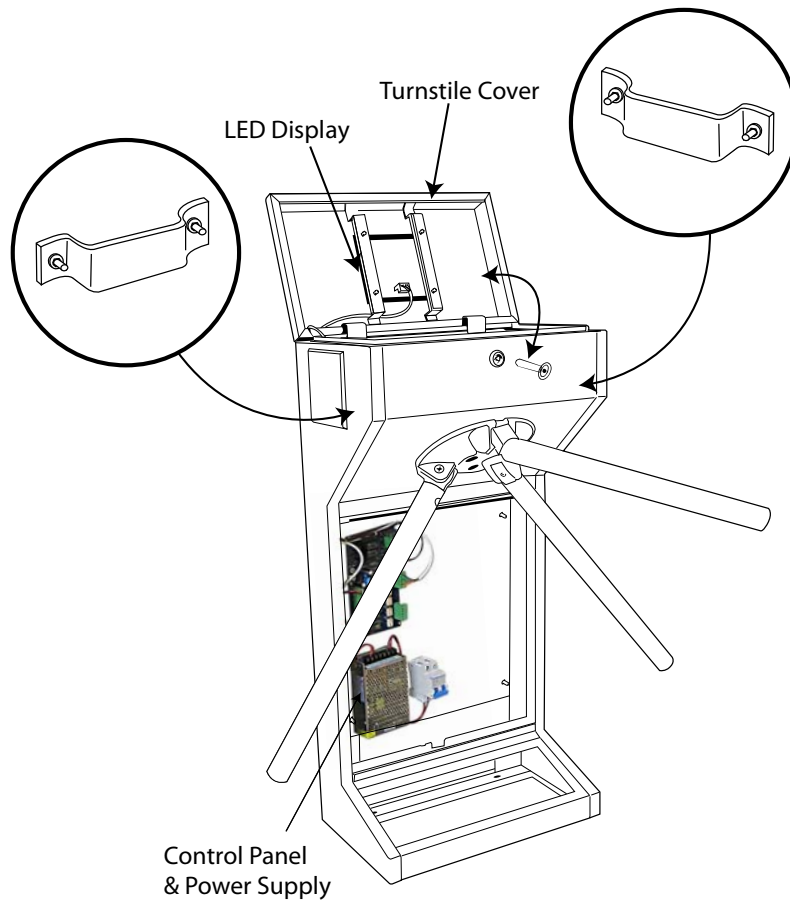

## Acrylic Plate

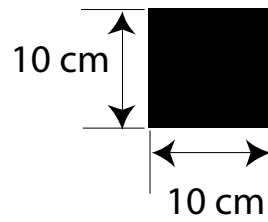
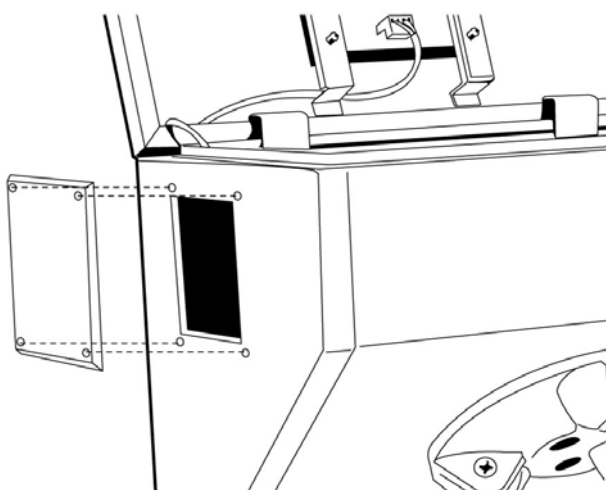

Dimension of turnstile hole

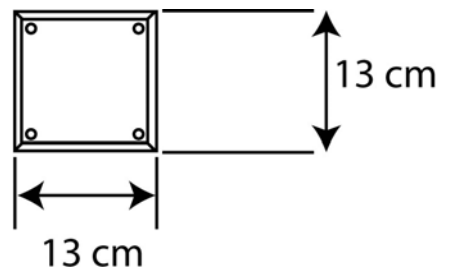

Dimension of Acrylic Plate

## Internal Spacing

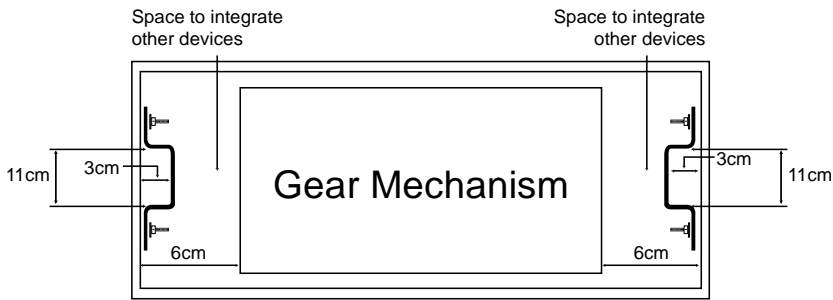

## Optional Accessories

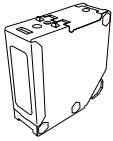

ESQ501

Infrared sensor - detect presence of human, vehicle and other object for extra safety

## Packaging Information

Turnstile Net Weight	52 kg
Turnstile Net Dimension	120 x 98 x 28 cm
Turnstile weight with packaging box	60 kg
Turnstile dimension with packaging box	125 x 103 x 33 cm

Authorized dealer:

### Disclaimers

Applications that are described herein for any of these products are for illustrative purposes only. Drawing does not necessary reflect exact assembly/installation. MAG makes no representation or warranty that such applications will be suitable for the specified use without further testing or modification.

MAG reserves the right to make changes, without notice, in the products, including circuits, standard cells, and/or software, described or contained herein in order to improve design and/or performance. MAG assumes no responsibility or liability for the use of any of these products, conveys no license or title under any patent, copyright, or masks work right to these products, and makes no representations or warranties that these products are free from patent, copyright, or mask work right infringement, unless otherwise specified.

© MAG. All rights reserved.  
Date released: 20 Oct 2011