

# GV-NET / IO Card (V2.3)

The GV-NET/IO Card is a RS-485 / RS-232 interface converter with 4 points inputs and 4 points relay outputs.

## Installation

Insert the GV-NET/IO card to an empty card slot. Connect the 20P ribbon cable to the video capture card as shown below. Connect one of the PC power supply's 4-pin-mini cable to the GV-NET/IO card's power input connector.

## Packing List

- ❶ GV-NET I/O Card x1
- ❷ 20P Ribbon Cable x1
- ❸ RJ-11 to DB9 Cable x1
- ❹ 4-pin to 4-pin Mini Power Cable x 1

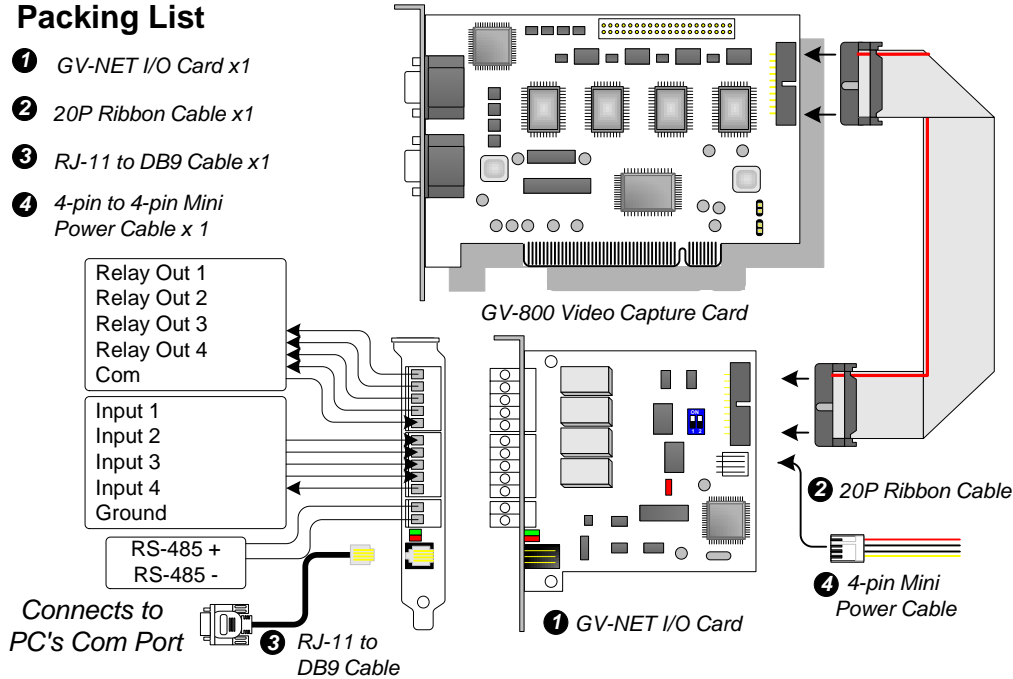

## Specifications

Input	Input	4
	Input Signal	5V DC (floating) / TTL
	High State	5V
	Low State	0V
Output	Relay Output	4
	Relay Status	Normal Open
	Relay Capacitance	2A / 30V DC; 0.25A / 250V AC
	Relay On/ Off Time	4ms / 4ms
Communication	RS-485 1,200~19,200 bps	
DC IN	DC 5V, 1A	
Environmental Conditions	0~50 degree C , 5%~95% (non-condensing)	
Compatible Card Models (H/W)	GV-600 V3, GV-650 V3, GV-800 V3, GV-900 V1.11 and GV-1000 V1.21 only	

## Connecting Output Devices

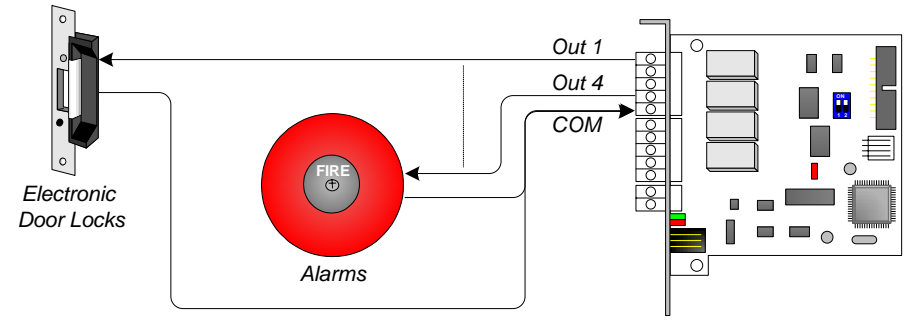

## Connecting Input Devices

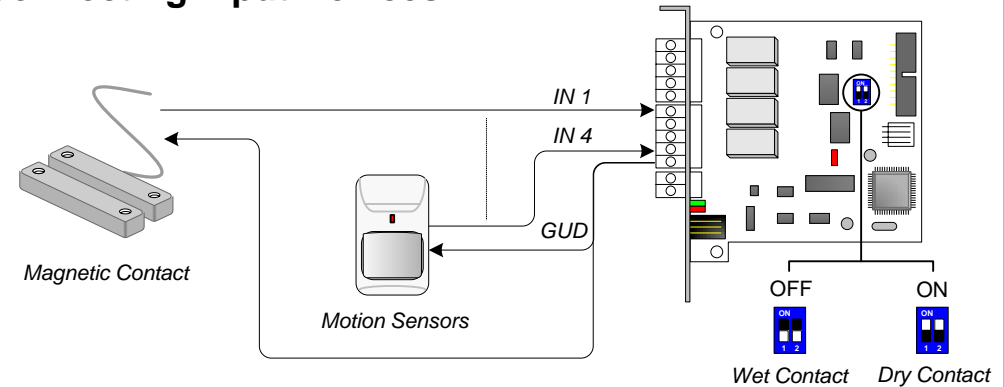

## Connecting RS-485 Devices (PTZ Dome / GV-IO)

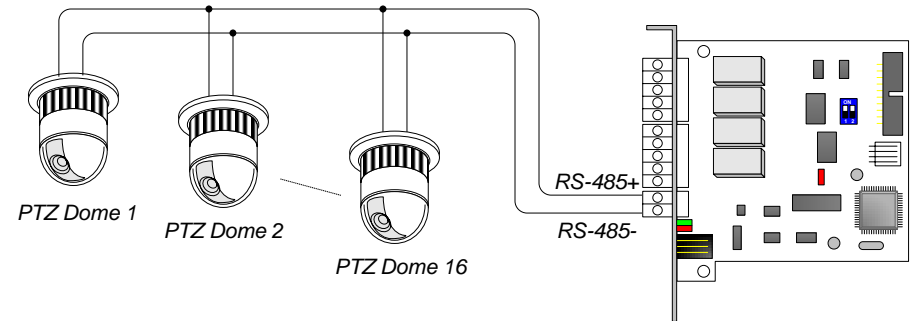

- ⚠ Caution:**
1. Use the switch for dry contact and 5V wet contact.
  2. GV-NET/IO card accepts either all dry contact or all wet contact devices. Don't mix two different contact devices to the same card. (Default Setting: Dry Contact)
  3. To prevent the noise interference in I/O operation, tightly screw the GV-IO card to the PC case.